



Rural Waste Management Field Handbook

A look at how to initiate and implement
rural waste management in Myanmar



switchasia



Funded by
the European Union



Who is this handbook for?

- 01** No access to municipal service:
This handbook helps community workers to make use of a step-by-step methodology for setting up a waste management system in a community which does not have any access to a municipal service.
- 02** Tried and tested structures
It is based on 7 years of experience working in rural villages in Myanmar and uses a structure like improvements in water sanitation and hygiene - WASH
- 03** For previously community development trained personnel
Before using this guide with communities, you should have received training in similar community development trainings like WASH.
- 04** The handbook is based on the e-learning course “Rural Waste Management in Myanmar” (<https://www.youtube.com/channel/UCfZ2XIWjAZqBMh-GFXnGd7Q>). This course builds the necessary basis for this handbook.

Dos and Don'ts for the community workers

Dos

- Be humble, listen to other, be tolerant and most important be patient
- Act local, think local, stay local
- Keep the aim in mind during all activities
- Be flexible and curious to local ideas and solutions
- Be inclusive and try to include minority perspectives

Don'ts

- Don't commit on actions you can not carry through
- Avoid over scientific or academic language
- Be respectful to local culture but don't give into gender/age/race discrimination
- Avoid over-incentivising community action

The Goal of R-SWM:

The ideal village from the perspective of SWM

The ideal SWM system in a village operating independently from any municipal waste collection system can be relatively advanced from the perspective of SWM. The system must be practical on one side while at the same time find mechanisms which incentivize reduction and segregation throughout all community activities. The workstream consists of 3 major pillars:

REDUCTION

- Segregation of waste at source and treatment organic waste on compound by feeding to animals and making compost
- Plastic reduction activities with focus on bags and purchasing pre-packaged products
- Periodic trainings in schools making students understand the local environmental threat but also the linkage to climate change, global pollution and biodiversity loss

COLLECTION

- Set up of infrastructure for households to dispose of inorganic waste (bins)
- A community led collection system collecting waste, enforcing source segregation and extraction of recyclables
- An oversight system which keeps collection operating sustainably relying on community support

DISPOSAL

- A community disposal site where waste does the least amount of harm to the community and nature

Key data to keep in mind

Waste composition in rural Myanmar

Generation : 0.22 kg/cap/day

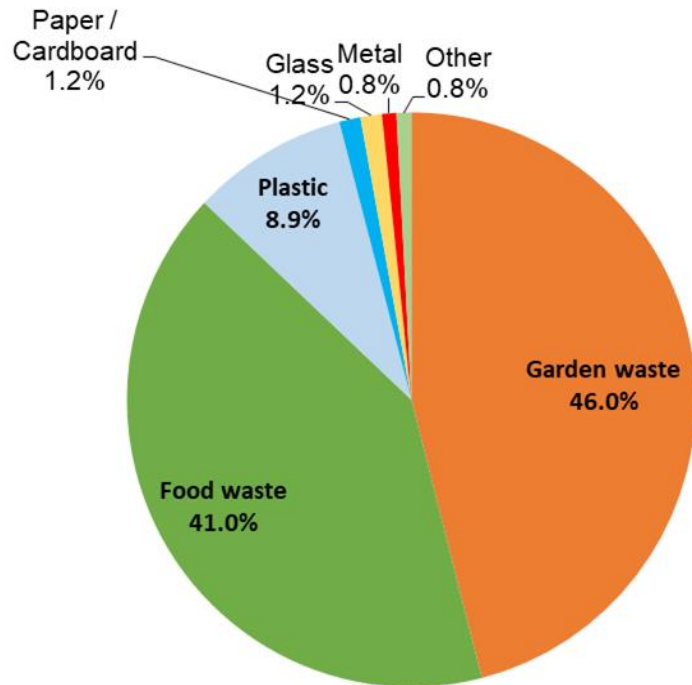

- Waste generation rate is 50% to 80% lower than in urban areas (0.22kg/cap/day)
- 80% to 90% of waste is organic
- Food waste (around 40%) is often treated sustainably (animal feed) already
- Garden waste is often burned mixed with plastic waste
- Plastic is the only component in the waste stream which requires a waste collection system
- Less than 10% of plastic waste has a potential of being recycled (mainly PET). HDPE and PP items have a higher reuse value.
- Main plastic waste items are: bags, sachets and flexible food package which are driving environmental pollution.

Key definitions

STEP

A step may contain one or more activities aimed at achieving one overall objective.

ACTIVITY

An activity is one specific action taken inside one step aiming at putting a piece of infrastructure in place or reach an understanding/agreement with a specific stakeholder.

TUTORIALS

Every activity is accompanied by a video tutorial which explains the activity in detail. The video is integral to understand the activity and should be watched before using this handbook.

MATERIALS

Most activities require some form of additional materials. This ranges from IEC materials for trainings, questionnaires for investigation or components to build infrastructure. Materials as provided in this guide can be either copied, used or adjusted to the specific local requirements.

Field capacity

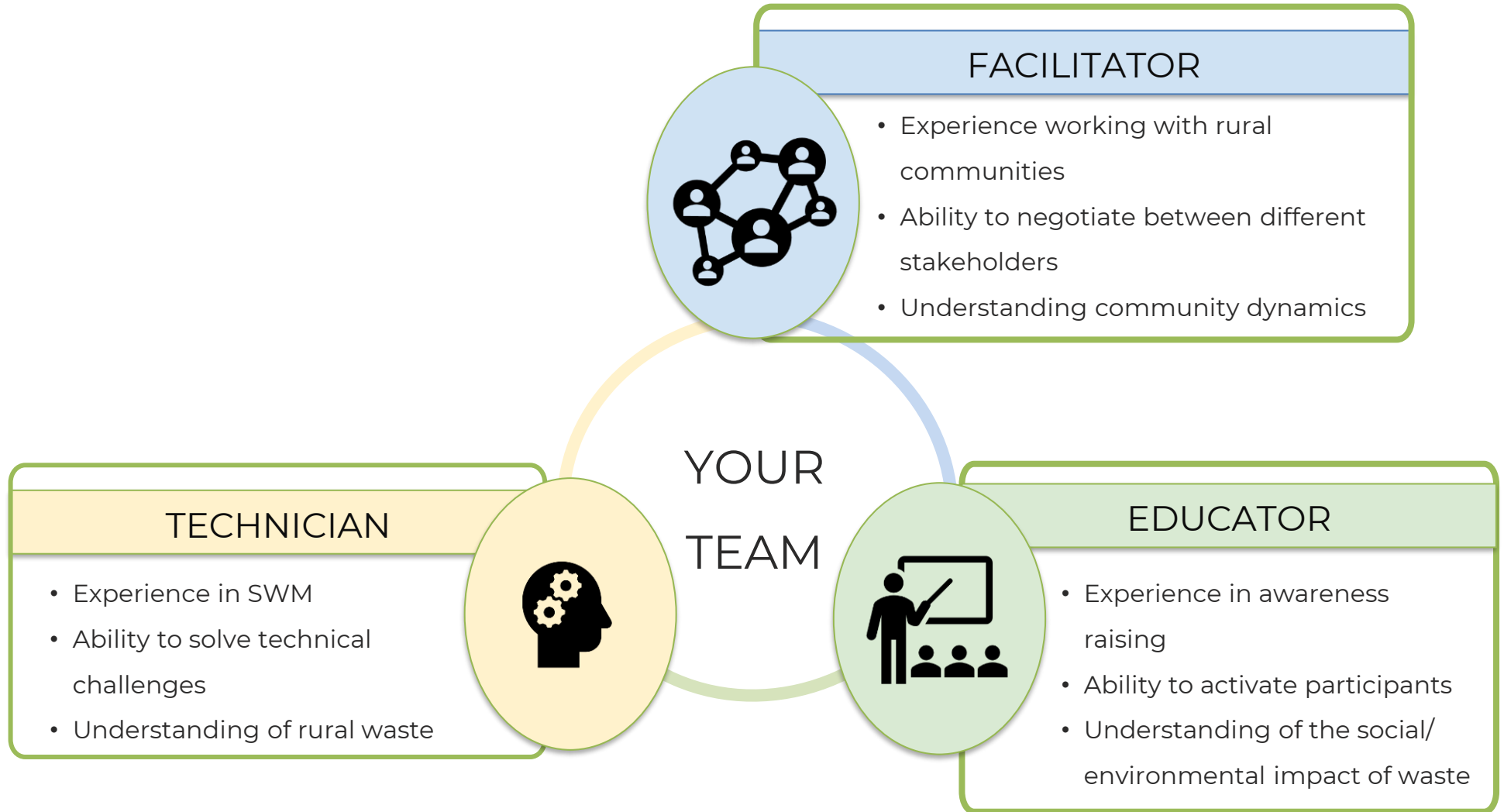

STEPS

ACTIVITY

1. Community introduction and observation

- Meet village leader
- Village tour (or) observation
- General meeting

2. Problem analysis with committee

- Participatory learning
- Community investigation (optional)

3. Setup a basic system

- Choosing final disposal method
- Construct incinerator (optional)
- Organic waste treatment
- Village clean up (optional)

4. Setup a collection system

- Action planning
- Bin making (optional)
- First collection day

5. Activate the community

- Engage households
- Engage schools
- Engage key stakeholders

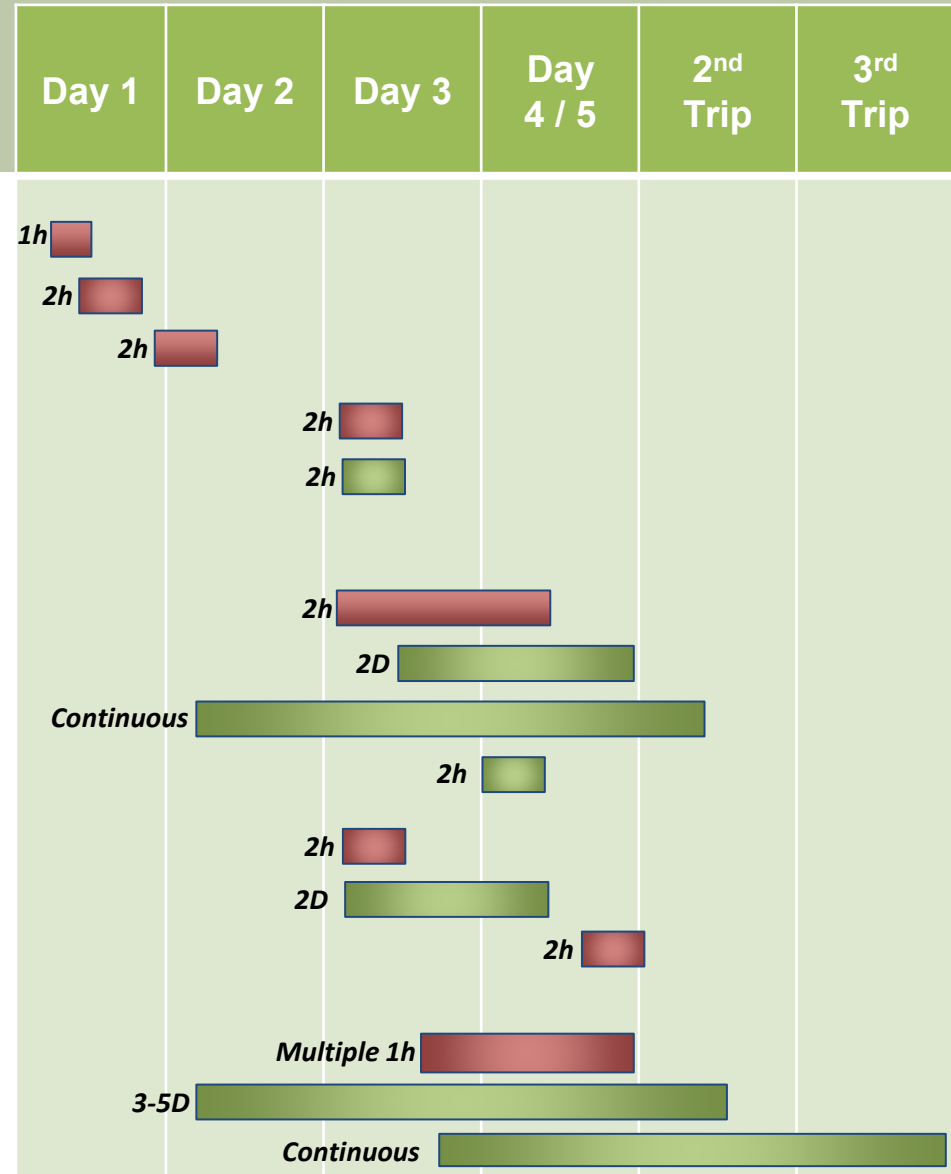

 Action is critical

 Can be neglected or delayed

Prepare
before
you go to
the field

STEPS	ACTIVITY	MATERIAL NEEDED
STEP 1	General meeting	Loudspeaker +Awareness Posters
STEP 2	Participatory learning	<ul style="list-style-type: none">• Awareness posters,• Bins & cards for waste segregation game• flip charts, crayons• Bluetooth speaker• Ice breaking game materials
STEP 3	Household training	Awareness training (as in step 2) and real waste for effective demonstration

1.1- Step 1 - Activity - 1

Meet village leaders



Your skill:
Facilitator

Purpose: Agreement from the village lead to set up a waste management system

What to do?

Time Needed: 1 hour

- Introduce the team and the reason for your visit
- Ask how they manage their waste and the existing SWM system
- Listen to their challenges with waste and their experience
- Plan for implementation and timeline
- Discuss next steps: observation, general meeting, formation of a waste committee, key stakeholders, waste disposal site;

Activity -Outcome Tree

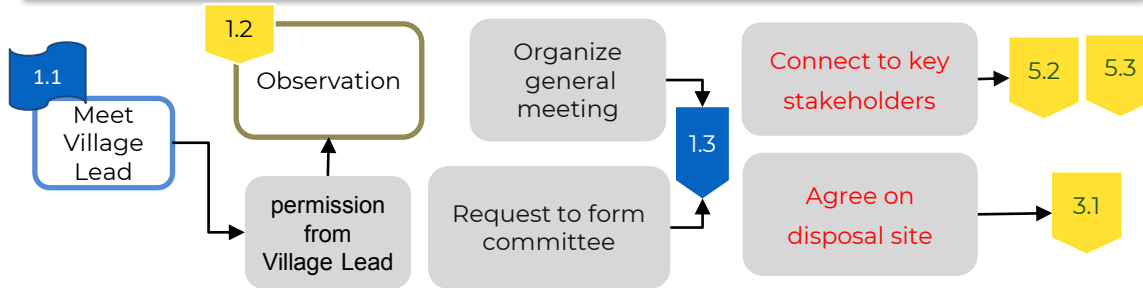

Stakeholders

Village Lead, (village committee members, CSOs, charity groups)

Place of Activity

Village lead home or office

Materials

note-book

Tips:

- Arrange the meeting before going to the village;
- Prepare an agenda;
- Look out for informal community leaders and issue interested people who join the meeting. They might be key to keep the actions sustainable
- Be aware in advance of what contribution your organization can provide and what the community will receive or need to contribute;
- Request to specifically invite youth, women and activists to the general meeting;

Challenges:

- The village leader
 - has little community influence or vice versa, acts authoritarian;
 - Is not interested in the topic or is sceptical about the work;
- Requires permission form certain government institutions to work in the village;

1.2 - Step 1 - Activity 2

Observation



ENG



BUR

Your skill:
Technician

Purpose: **Understand the village situation**

What To Do?

Time Needed: 2 hours

Organize a local village guide and assess:

- Existing system available? (See next page)
- Roadside observation on waste and local dumps
- Assessment of possible places for infrastructure
- Understand social integration structure

Activity -Outcome Tree

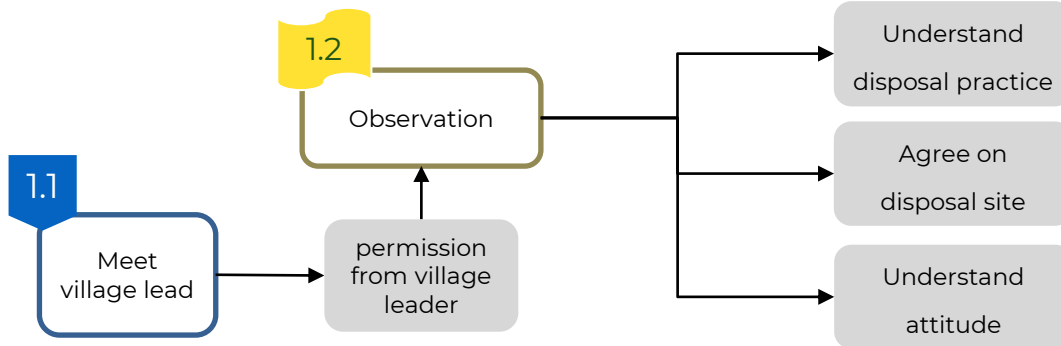

Stakeholders

Village guide,
Villagers, shop
owners, recyclers

Place of Activity

Around the Village,
some households
and shops

Materials

[Questionnaire for
HH and businesses](#)
Note-book, pen,
camera for
pictures



Tips:

Be curious during the observation and ask the community until you understand the current waste situation.

Talk with village guide when walking around the village.

Speak the with main waste managers in the village to understand the waste flow: housewives, shop owners, waste collectors, recyclers, etc..

Understand how organic waste and food waste is managed.

Communicate with recyclers if existing and the items they buy.

Challenges:

No local guide available

Challenge to choose a final disposal site

Your experience is not matching well with the areas challenges

1.3 - Step 1 - Activity 3

General Meeting



Your skill:
Facilitator

Purpose: **Community agreement to set up solid waste management in the village.**

What to Do ?

Time Needed: 2 hours

- Introduce the team and the reason you come to the village
- Reflect on the waste situation in the village..
- Explain about the project and purpose
- Discuss if they agree to work on this topic and receive common approval
- Select/ elect a working committee
- Commitment by households and other stakeholders to participant in awareness training and other activities.

Activity -Outcome Tree

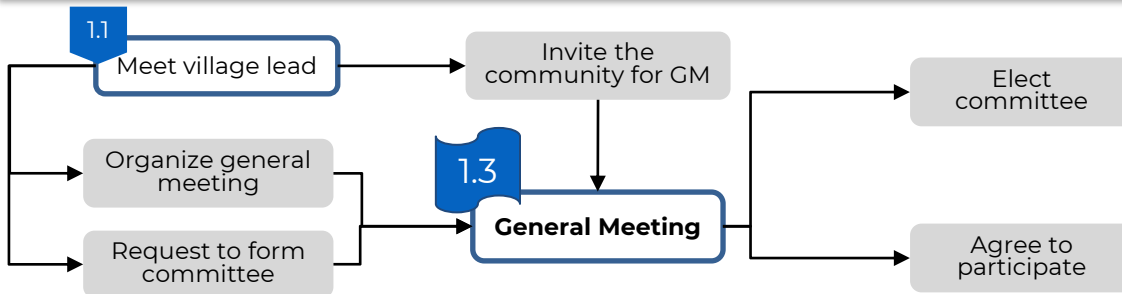

Stakeholders

All villagers (especially civil organization, youth, charity leaders, activists)

Place of Activity

Community Hall, monastery, school

Materials

Loudspeaker,
Awareness
[Vinyl](#)



Tips:

Must include VL, CSOs, youth, and activists;
The meeting should not be longer than 1:30 hr;
Sit or arrange the place in a circle to increase participation;
Listen carefully to impacts of waste they are experiencing;
Explain the support you can provide;
Encourage the committee to be inclusive to gender, age and minorities;
Committee should be an odd number and a maximum of 9 person in the initial step;
Let community vote on committee members;
Introduce the committee to the community to make it official and transferring the authority and responsibility;
Use plastic free refreshment;

Challenges:

Decision makers, CSOs, activists and youth do not participate in the meeting;
No volunteers to join the committee;
People who join the committee don't understand the work nature;
Community attend the meeting for incentive or wrong invitation approach from the village lead;

2.1 - Step 2 - Activity 1

Participatory learning with waste committee



Your skill:
Facilitator

Purpose: **Build a strong group to create a clean environmental for the village**
The committee clearly understands the waste situation in the village.

What to do?

Time Needed: 2 hours

- Introduction and Ice-breaking
- Village mapping to understand the waste flow
- Awareness raising on waste / plastic
- Discuss with them the situation when you had during the observation

Activity -Outcome Tree

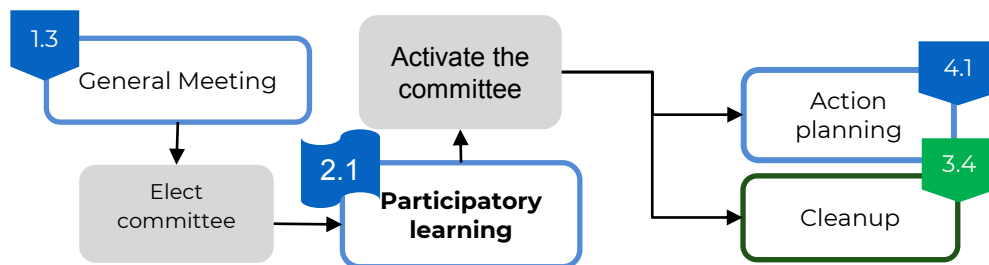

Stakeholders

Place of Activity

Materials

Waste
Committee

Meeting room,
Religious building,
school

[Ice breaking game and Waste segregation game materials](#)

- IEC material for awareness raising (hand drawing on old vinyl)
- White board / flip chart and soft pens
- Or crayon for waste flow diagram
- Bluetooth speaker



Tips:

Create team spirit through ice breaking activities.
Be visual and local in your explanations.
Mapping of existing situation as well as stakeholders creates a good common understanding;

Challenges:

The elected committee does not show up in full.
Committee is not active.
Gender equality problem based on culture.

3.1 - Step 3 - Activity 1

Defining a Dumpsite



Your skill:
Technician

Purpose: **Set up a common and official dump site in line with the waste disposal system**

What To Do ?

Time Needed: 2 hours

- Discuss with the committee and the village lead the preconditions for the dump
- Find a suitable place for final disposal / upgrade informal or current dump sites.

Activity -Outcome Tree

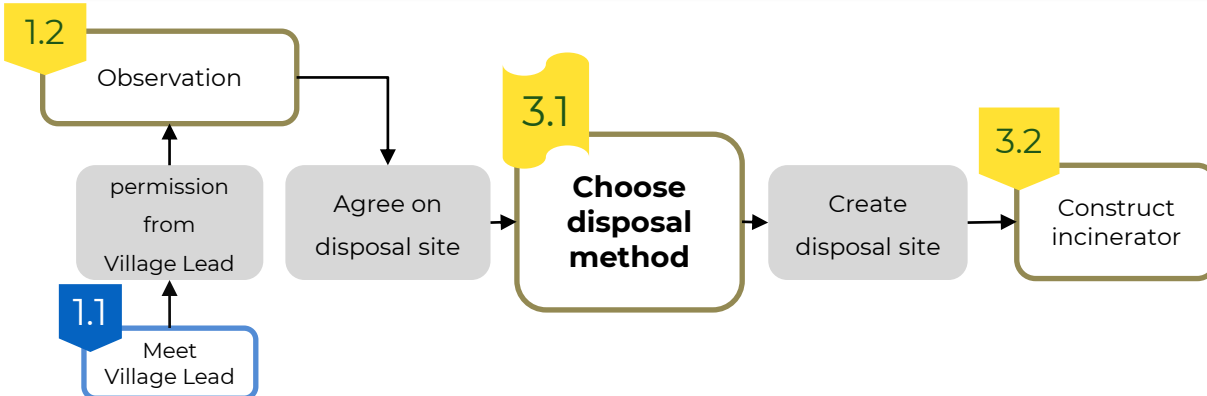

Stakeholders

Village Lead,
Waste Committee

Place of Activity

at the dump

Materials

[Defining dumpsite and incinerator design](#)

Tips:

Make sure you well understand the preconditions to select a final disposal site;
Emphasize on different methods of segregation and treatment (organic waste, recyclables) and include infrastructure if required;

Challenges:

No authority of village leader to commit land for the disposal site;
Challenging to decide the place of final dump as it is often a trade off between the environment and community due to land scarcity;

3.2 - Step 3 - Activity 2

[Construct Incinerator \(optional\)](#)



Your skill:
Technician

Purpose: **Improve burning heat of waste with a simple incinerator**
Allow final disposal using a minimum of space

What To Do?

Time Needed: 2days

- Build an incinerator
- Finding a suitable place for the incinerator
- Digging pit below the incinerator for the ashes
- Provide PPE and explain the importance of using it (specifically the masks)
- Explaining the incinerator design and how it works to the committee.
- Demonstrate the functionality by burning a small amount of waste

Activity -Outcome Tree

3.1

Choose disposal method

Create disposal site

3.2

Construct incinerator

Stakeholders

Place of Activity

Materials

Waste Committee

Metal workshop and Dump

[Defining dumpsite and incinerator design](#)

- Electricity, welding machine, and rebar (production cost: 200USD estimate)
- Dry inorganic waste for demonstration (Can get after clean up: Activity 3.4)



Tips:

The incinerators is best placed close to an entrance road of the village so that it is accessible, but far away from any housing
 In a self dropping system, provide user training to the community.

Make sure to pre-order the incinerator so you have it on the first collection day.

Challenges:

Mixed waste, wet waste, rain;

The metal is not well heat resistant and bends;

No welding shop in village and difficult to transport the incinerator to the village;

Low quality welding;

Design and measurements of incinerator

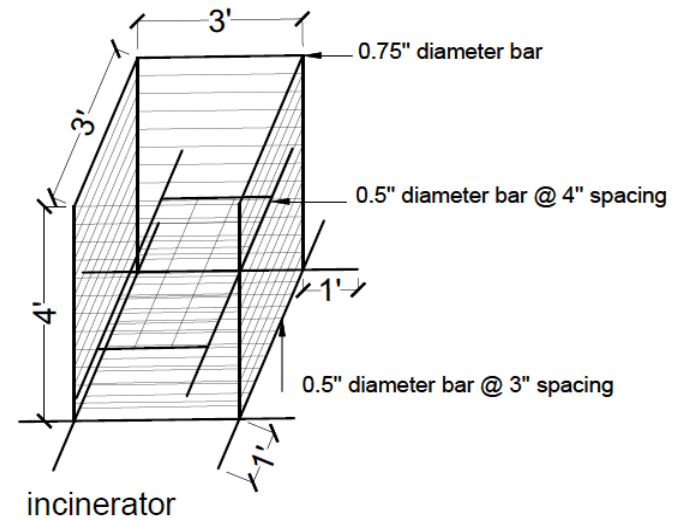
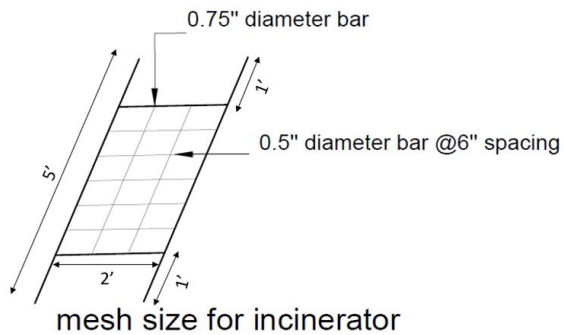
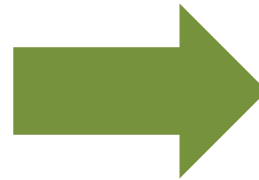
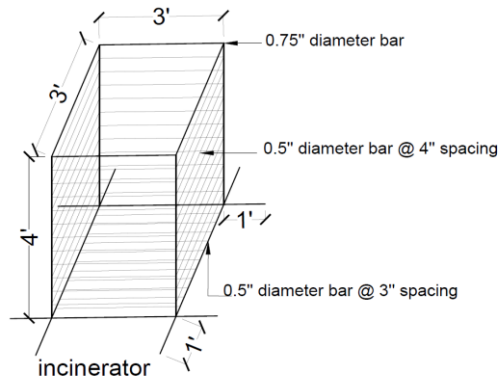

3.3. - Step 3 - Activity 3

Organic waste treatment



Your skill:
Technician

Purpose: **Organic waste is not entering the waste collection system**
Community clearly understand the difference between organic and inorganic waste and treats the waste different.

What To Do?

Time Needed: 1 hour for demonstration

- Observe local (best) practices on food waste and garden waste
- Create some pilot compost piles with households/ schools/ community centre, etc.
- Promote segregation and treatment through the waste committee

Activity -Outcome Tree

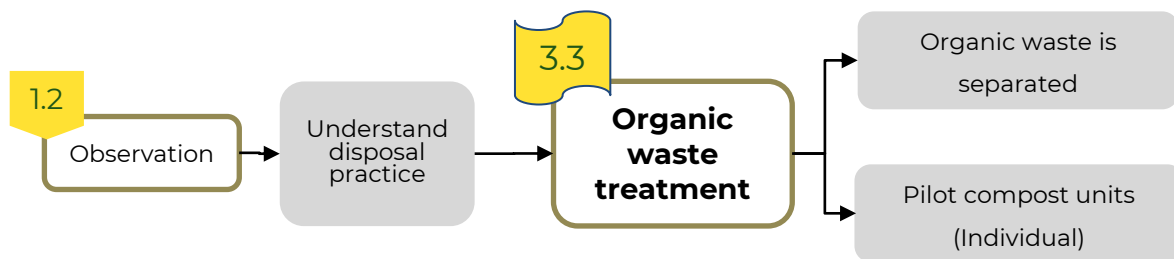

Stakeholders

Place of Activity

Materials

Waste Committee and households

Household who is doing composting

bamboo pallet/ Fishing net/ Iron mesh,
[Composting Pile design](#)

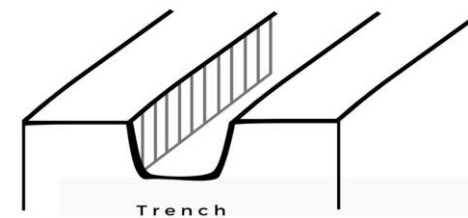

Trench



Pit Compost



Duration(3 - 6 months)

Tips:

choose least workload, infrastructure and combine with garden activities; individual composting is more sustainable for the community; demonstrate to committee and households. chopping and layering speeds up the process; In rainy season, add more water absorbent material to balance the moisture of the compost since there will be no dry leaves.

Challenges:

community is used to burn their waste; concern of snake and other pests; looks dirty or has no space; Non farming communities have low interest and knowledge on treatment;

WHAT TO COMPOST

Ingredients materials for compost

Brown

Green

Dry leaves / Branches

Vegetable cut

Paper / Cardboard

Kitchen waste

Saw dust / Egg shell

Flowers / Grass

UNDER CERTAIN CONDITION

Cooked food
Sour organic
chillies, fats and grease

WHAT NOT TO COMPOST

Inorganic waste

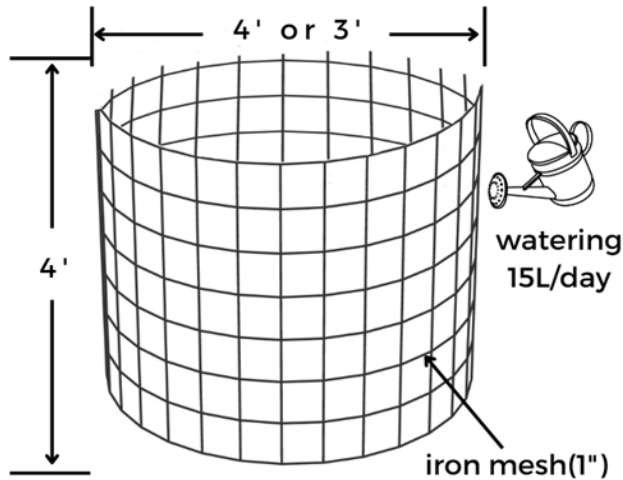

Compost Pile

materials



iron mesh



fish net



bamboo mesh

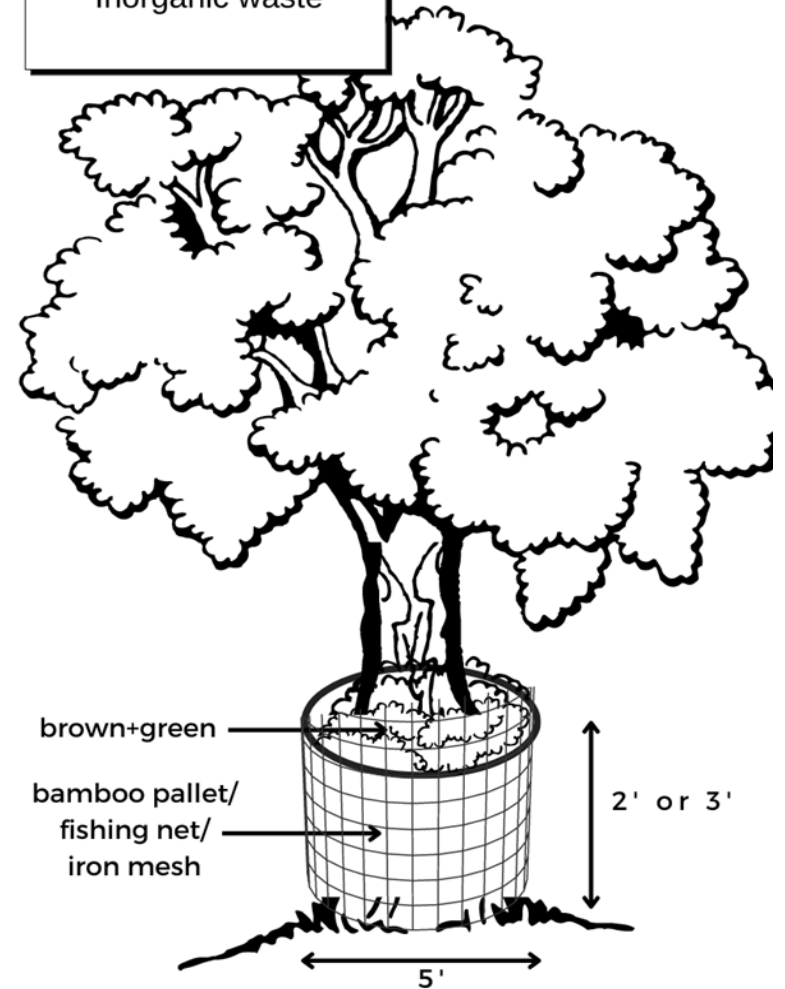

Duration(3 - 6 months)

3.4 - Step 3 - Activity 4 Cleanup



Your skill:
Educator

Purpose: **Community is aware of the set up of a waste management system, understands waste segregation and where to dispose of inorganic waste.**

What To Do?

Time Needed: 1-2 hours

- Help community to organize clean up by inviting groups, individuals and children to participate
- Introduce the clean up by telling a story and teach a song to the children:
- During clean up, show which waste should be collected for final disposal
- Clean up focusing on plastic and organic waste separately

Activity -Outcome Tree

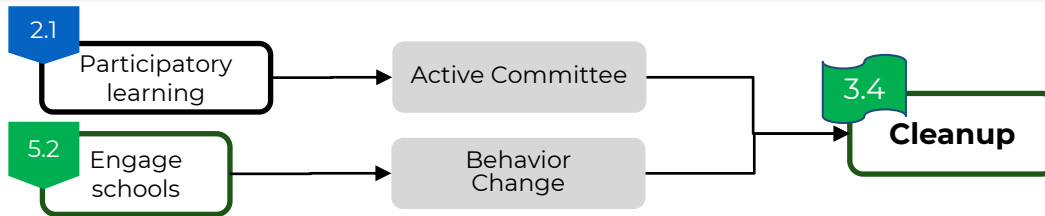

Stakeholders

Village Lead,
Waste
Committee,
CSOs, children,
community

Place of Activity

In the Village,
Exp – Village
Crowded & Festival
places, View point,
School compounds

Materials

- PP-bags, bamboo or other locally produced baskets
- reusable/construction glove
- speaker

Tips:

Be sure that the final disposal site is selected or that an incinerator is available;

Focus on areas which are very visible in the community and easy to clean (not too muddy or in the water or under houses) like roadside, markets, religious areas, village center;

Invite passersby to participate;

Collect **ONLY** inorganic waste for disposal;

Lead by example and participate in clean up while you also help with correct segregation;

Use the reusable gloves and old fertilizer bags as waste bags instead of using single-use items;

Be careful with needles and broken glass bottles (especially for children);

Use plastic free refreshment by relying on local products;

Incinerate collected plastic together with committee;

Challenges:

Handle a large group of young children;

Only few show up or crowd of groups;

Plastic can be found in the stream but difficult to collect;

Weather events;

4.1 - Step 4 - Activity 1

Action Planning



Your skill:
Facilitator

Purpose: The committee takes an informed decision on the collection method. Committee clarified all the actions to be taken and the responsibilities of the members to operate the system. Activity can be conducted directly after 2.1

What To Do?

Time Needed: 2 hours

- Discuss different collection methods.
- Decide on the preferred system.
- Draw an action plan with the committee including responsibilities.
- Discuss financial sustainability

Activity -Outcome Tree

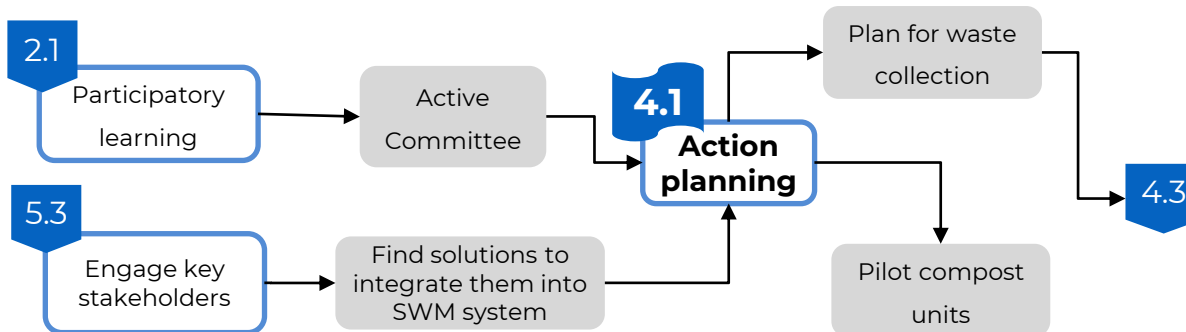

Stakeholders

Waste Committee

Place of Activity

Community Hall,
Religion Building,
School

Materials

[IEC material to explain the different collection method and segregation game](#)



Tips:

Facilitate the discussion rather than lead it and help integrate local ideas;
Use start and strengthen approach;
encourage leadership and have a short follow-up meeting with village lead;
Make sure to clarify responsibilities with actual names in the action plan;

Challenges:

Committee prefers advanced systems which are high maintenance;
Legitimacy - limited decision-making power;
Start without initial funding;
Community focus is on incentives they could receive rather than on the developing practical solutions;



Self Dropping System

Requirements:

- Waste segregation from HH level
- Every HH disposes of their waste at the dump
- Landfill or incinerate

Preferred system in:

- Small communities
- with low social integration (Less unity)

Strength:

- Less workload
- Low-cost system

Challenges:

- Many will continue to litter waste and multiple illegal dumps will appear.
- Sustainability of infrastructure
- Less chance of waste segregation



Collection point System

Requirements:

- Forming a waste committee.
- Waste segregation from HH level
- Need to maintain public or semi-public bins
- Frequent and reliable collector
- Landfill or incinerate

Preferred system in:

- Large communities with strong leadership
- With medium to high social integration

Strength:

- Less workload comparing to door-to-door collection system

Challenges:

- Less chance of waste segregation from HH
- Public bins can be messy (use semi public bins)
- Need funding to operate the system
- Less chance that households are willing to pay

Step 4 - Activity 1 Financial Sustainability

Your skill:
Facilitator

PAY AS YOU DROP/PERIODICALLY

- The committee operates as a social business gathering fees for the waste collection
- Preferred system in:
 - Large communities with strong leadership
 - With medium social integration
- Challenge (Pay as you Drop): People who don't pay still litter the waste; Waste collectors have difficulties receiving the fees. No authority in communicating with the households.
- Challenge (periodic): Fee collectors need to receive commission to be incentivized so in the initial step, collecting fees periodically will be easier

DONATION

- The committee is organized as a voluntary group that conducts periodic collection and receives support while the waste is dropped.
- Preferred system in:
 - Large communities with strong CSO support but maybe a problem in leadership
 - Have strong ownership sense of the community
 - With medium social integration
- Challenge: sustaining the system with irregular income over a long time.

VOLUNTARY MEN POWER & SMALL AMOUNT OF COLLECTION FEES FOR EXPENSE

- The committee is organized as a voluntary group that conducts a weekly collection organized as a community event.
- Preferred system in:
 - Small communities
 - With high social integration
 - High ownership sense
- Challenge: sustaining the system without financial resources over a long time.

ACTION PLAN

ITEM	ACTION	RESPONSIBLE PERSON	TIMELINE	FUNDS
Collection system	Self Dropping System/ Collection points system/Door to Door Collection System	Who will collect waste?	Schedule for collection	Estimated funds needed
Vehicle	Rent/ buy: Push cart/ Hanger for motorcycle/ 3 Wheeler	Who will buy/ rent the vehicle?	When to buy/rent?	Cost for vehicle: rent /buy?
Bins	Private, semi public, public	Who builds/ maintains the bins?	When to install the bins	Costs of bin making
Fee collection	None/fixed amount / Donation based/ Periodically	Who collects fees?	When?	Amount of fee?
Treasury	Hold funds/ Transparency	Who holds the funds?	When to report to committee?	
Public Relation	Social media page or group/ village meetings/ complain	Who keeps communication alive?	How often to engage?	
Plastic reduction working group	Reduce plastic usage in the village	Who facilitate between business and consumer?		Are there funds available for campaigns, etc.?
Dump Management group	Monitor segregation, disposal and incineration	Who controls the dumpsite?	How often need to monitor?	
Organic waste working group	Increase the usage of composting and reduce burning?	Who will engage villagers?		

4.2 - Step 4 - Activity 2

Bin Making



Your skill:
Technician

Purpose: **Create a sustainable bin system in the village.**

What to do?

Time Needed: 2-3 Days

- Discuss and decide on the most preferred bin design for the village.
- Build bins with the committee or find a carpenter depending on design.
- Place the bins at strategic places and receive aid from surrounding houses to maintain it

Activity -Outcome Tree

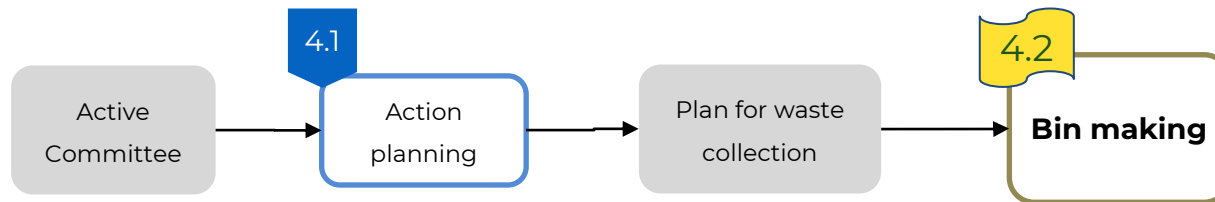

Stakeholders

Place of Activity

Materials

Waste Committee

Community hall or workshop

[Locally available material \(can be often made from waste\)](#)



Tips:

- Observe local materials and existing best practice bins;
- If there are existing bins, understand the disposal methods
- Emphasize on private and semi-public bins.
- Be aware of animals (cows, goats, rats, etc.)
- Place bins at -
 1. Junctions
 2. Viewpoints, markets, gathering areas, schools;
- The bins should be: cheap , open at the bottom to let rainwater out, NOT plastic bin, easily replaceable with local materials (Bamboo, Fishing net and Gunny Bags).

Challenges:

- The community wants new plastic bins.
- If the collection is not operating well, the bins will overflow;
- Bin sustainability;
- Free-grazing scavenging system (by animals: avoid food waste in these bins)

4.3 - Step 4 - Activity 3

First Collection Day



ENG



BUR

Your skill:
Facilitator

Purpose: **Kickstarting collection**

What To Do ?

Time Needed: 2 - 3 hours

- Pre-announcement before the collection day
- Prepare for collection day.
- Collect inorganic waste from the community
- Bring to the final disposal site.

Activity -Outcome Tree



Stakeholders

Place of Activity

Materials

Waste
Committee/
HH

Around the
Village

Collection vehicle
Waste bag (Large
and small)
Loudspeaker
Lighter



Tips:

- One member go ahead, use loudspeaker and announce the waste collection before the vehicle arrives;
- Tell the community during collection that segregation is crucial for operating the system.
- Community needs to bring the waste to the vehicle.
- Separate Recyclables during collection.
- Depending on the village, committee members can be divided into smaller groups (collection and incineration)

Your final disposal site should be completed and able to accept waste.

Challenges:

- Mixed waste, or wet waste because of rain
- syringe and other toxic/hazardous waste
- do not have suitable gloves for needles and broken glass

5.1 - Step 5 - Activity 1

Household Training



Your skill:
Educator

Purpose: Households have a basic concept of waste, waste segregation practices and know how to support the waste collection system

What To Do?

Time Needed; 1 :30 Hour and multiple session

- Awareness-raising with household members.
- Discussion on their support for the collection system.
- Segregation game
- Individual Household outreach

Activity -Outcome Tree

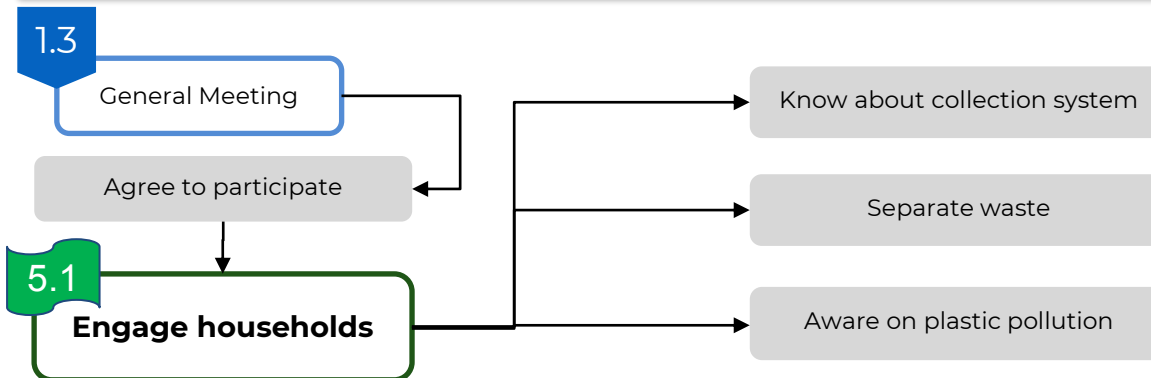

Stakeholders

Place of Activity

Materials

Community Members,
Waste committee

Community Place/hall,
religion building, school,
one of the house,
Shady place

- [Vinyl, bins, cards](#)
- Real waste (mixed)
- Bluetooth speaker



Tips:

- Village lead and committee should invite the households.
- Conduct the session separately for different areas in the village.
- Use local language.
- Refer clearly to the waste management system as decided by the waste committee
- Demonstrating waste segregation.
- Ask their willingness to pay collection fee by raising hands.
- Although children are challenges for training, it is more effective to tell impacts of plastic/waste to children
- It is better having a member to take care of the children.
- Making the funny conversations is crucial to create the open discussion between educator and community.
- Impacts- link with local context.

Challenges:

- Many sessions are needed in a larger village.
- Finding a good time where women can join.
- Children join the meeting.
- Less people attend the training

အိမ် တွင်းစွန့်ပစ် အပွိုက် စီမံ ဆုံးမဲ့မှု သင်တန်း



Time: 5min
Ice breaking:
use some common
Ice-breaking
activities to make
the participants
laugh and be more
active.

Time: 5min
Ask the participants if
they know why are they
here and discuss
general issues they have
with waste/plastics

Time: 3min
 Before showing answer:
 Ask them how they define
 waste?
 Aim: waste is not all the same

အမှိုက်ဆိုတာ ဘာလဲ

- အမှိုက် ဆိုသည်မှာ ပြန်လည်အသုံးပြု၍ မရသော ၊ အသုံးမဝင်သော အရာများကို ဆိုလိုသည်။

အိမ်တိုင်းမှာ ရှေ့ဆုံး ထွက်ရှိနေသော အမှိုက်များ

Time: 8min:
 Before showing answers:
 Ask the common types of
 waste they know?
 Where this waste is going?
 What is the further use of
 this waste?
 What happens to organic
 waste, paper, metal and
 glass?
 Aim: only plastic has no
 further use (except for those
 which can be recycled) and
 therefore becomes the main
 polluter.

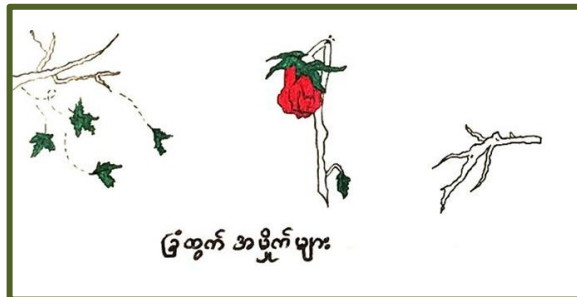
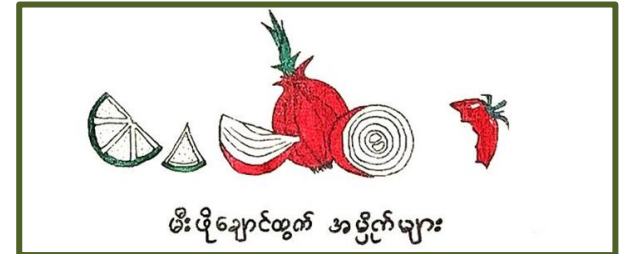

စွန့်ပစ်အပွိုက် စီမံခန့်ခွဲမှု

Before showing the answer:
Ask: how they are managing their waste currently?
Aim: They themselves realize that their habits and solving ways are destructive.

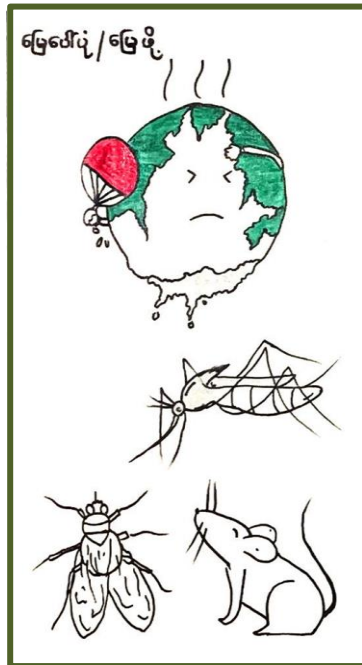

Explain:
Impact of the open burning with health issues.
Highlight how oxygen and clean air quality is crucial for the human being.

Explain:
Impacts of open dumping by linking with pests, general pollution, etc.

At the end of this slides:
link all the impact with next generations health and wealth. Stimulate their emotions.

Ask: Do you eat your plastic waste?
Link plastic with the food chain and that we do eat around 5g of plastic per week

ပလတ်စတစ်နှင့် ကျန်းမာရေးအကျိုးဆက်များ

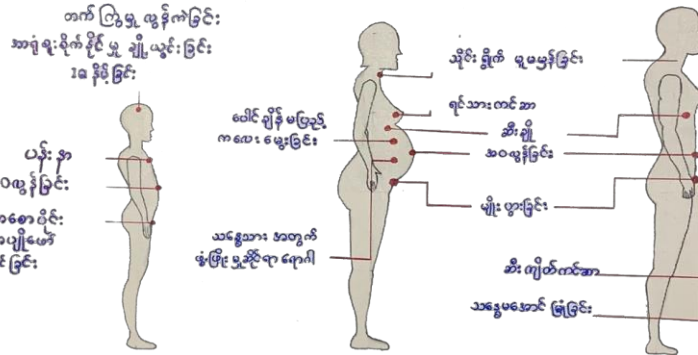

- ရှိမိခြင်း
- မျိုးချမိခြင်း
- အရေပြားနှင့် ထိခြင်း



Explain

Ask: common sicknesses and discuss if they relate to toxic chemicals.

Explain impact of plastics and toxic chemicals to the human body.

Common high trigger effects are: reproductive health and cancer.

Tips: Use the information got from observation

ပလတ်စတစ်၏ အန္တရာယ် ကွင်းဆက်

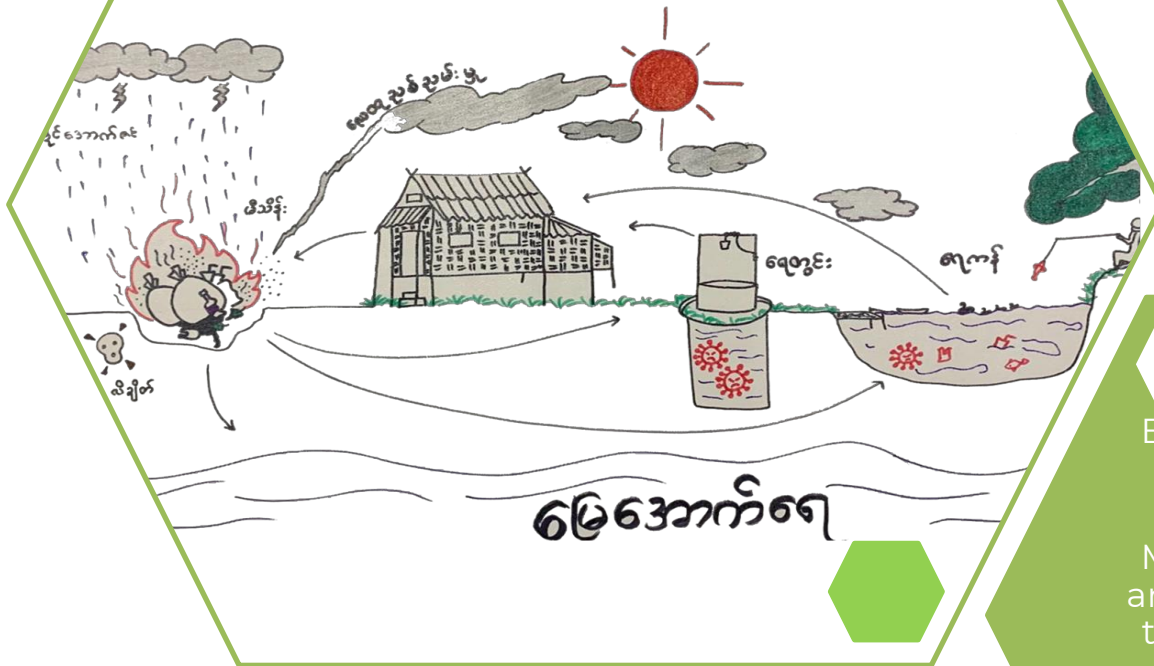

Explain: Leachate – Ground water pollutes from open dumping

Movement of microplastics and toxic chemicals released to air, water and soil, which enters the human body.

Aim: Realize that plastic is toxic and their practices affect themselves

ပိုက်ဆံပေး၍ ဝယ်ရသော အပို့ကံ



Explain: Consumers get persuaded by shiny products but with poor value content. The money they pay for these products finally becomes community burden in managing the package. All the money they pay is not staying with the community but is given to large brand owners.

Aim: realize the impact of consumption decision and the value of local production and consumption.

Tip- Highlight on economy

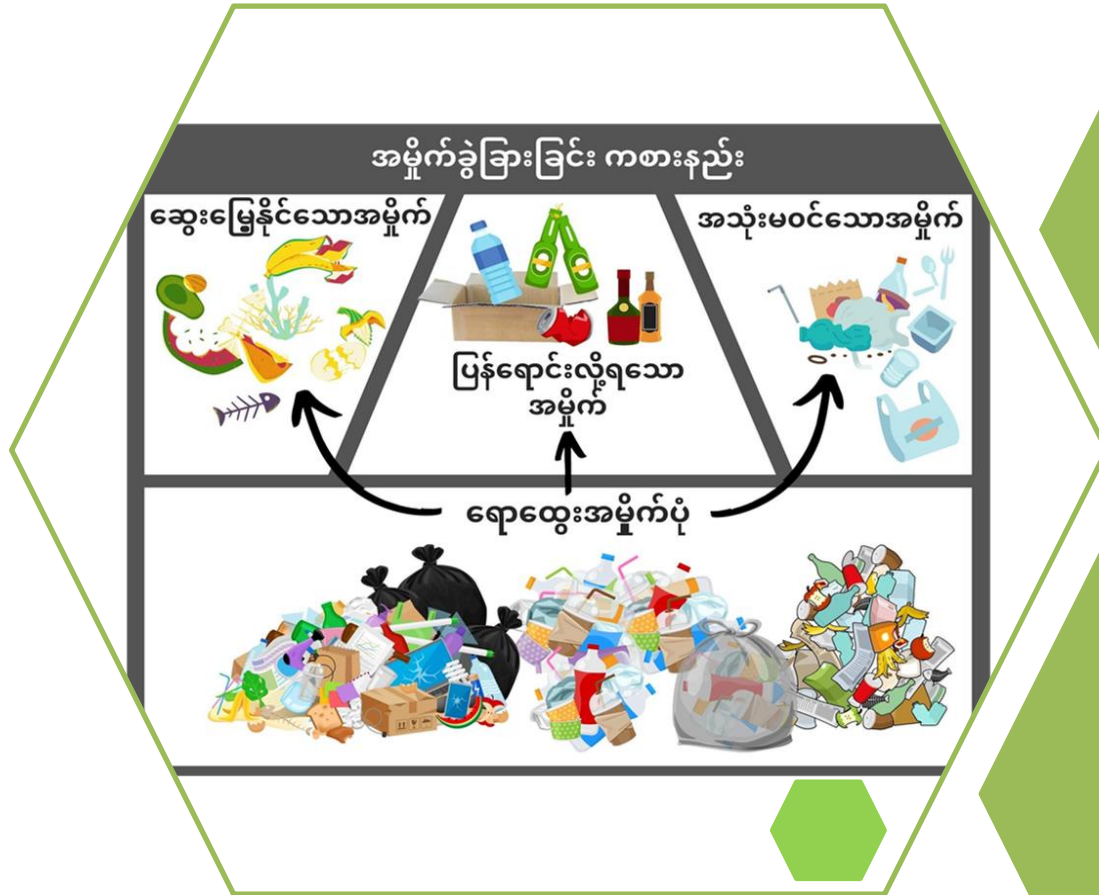

Time: 15 mins
 Game activities:
 Aim: Better understanding on waste segregation
 (Need to prepare real mix waste for the game)

Explain: prepare 3 bins in which participant sort a pile of mixed waste. Create a challenge by having two groups who have to compete

Discussion

- After completing the awareness training, work with the participant on following points:
 - ❑ make some questions regarding the training to evaluate their understanding
 - ❑ Connect their understanding to future challenges on this topic
 - ❑ Asking/Confirming their commitment to involve in the system and explain that the system needs their participation.
 - ❑ Build trust between the waste collection committee and the community to create a good basis for them to resolve upcoming challenges.
 - ✓ Explain the value of the waste committee to maintain this system.
 - ✓ Highlight that they all need to work together to create a sustainable system.

5.2 - Step 5 - Activity 2

Engage Schools



Your skill:
Educator

Purpose: **The school takes a leading role in good practices around waste reduction segregation and disposal**

Main Activities

Time Needed: 2-3 Days

- Introduction and observation
- Awareness raising to teachers
- awareness raising to primary, secondary and high schools
- Introduction to waste management activities at school

Activity outcome tree

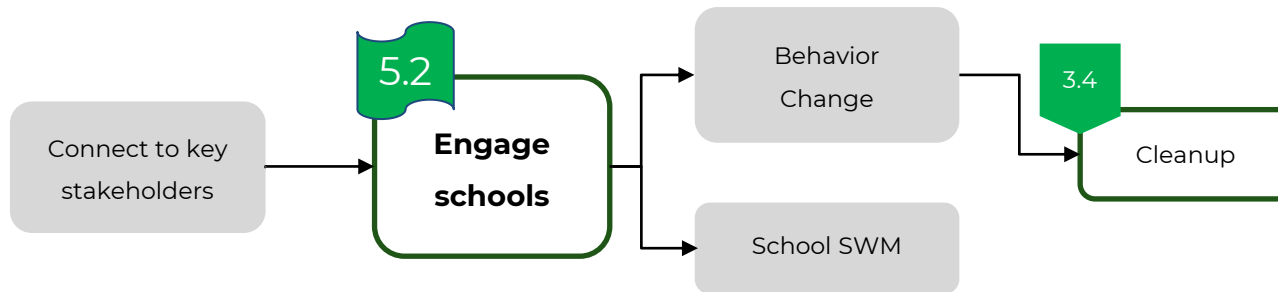

Stakeholders

Teachers,
Students, School
guard

Place of Activity

School

Materials

[Handbook](#), [Vinyl](#),
[Songs](#),
Bluetooth speaker



Tips:

- Work out a timetable with the teachers to repeat the activities
- Transfer ownership of the activities by including teachers from the start and if possible let them lead

Challenges:

Extra curriculum - activities are low priority for teachers

5.3 - Step 5 - Activity 3

Engage Key Stakeholders



Your skill:
Facilitator

Purpose: **Key stakeholders take part in the waste management system.**

What To Do ?

Time Needed: depends

- Discuss in small groups or individually with key stakeholders:
- Provide them with technical support as well as integrating them into the community collection system
- Request their support for the community collection.

Activity Outcome Tree

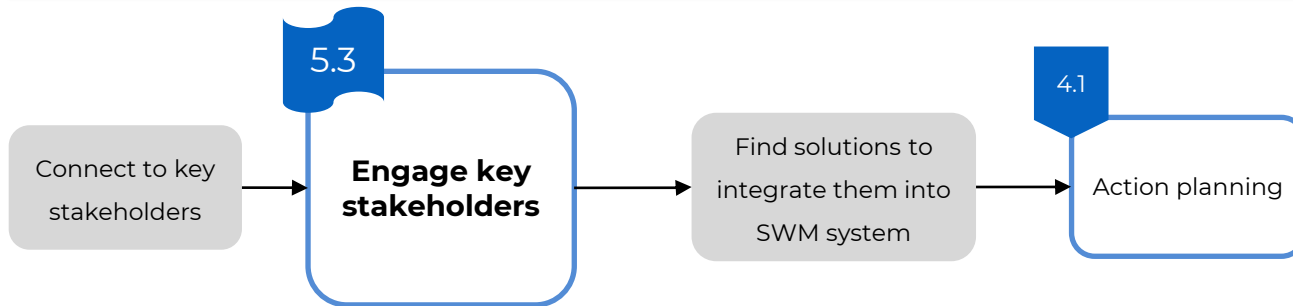

Stakeholders

Market, Religious Institutions, Hotels, Restaurants, Shops

Place of Activity

At stakeholders' place

Materials

Campaign Posters,
Materials for composting pile



Tips:

- Try to facilitate between the needs of the waste committee and that of the stakeholder
- Supporting key stakeholders can lead to long-term positive effects in the area.

Challenges:

- Developing specific solutions is time-consuming and requires a decent amount of understanding of the stakeholders' operation.
- Stakeholder has no decision rights on the local level

Key

Abbreviations &

Definitions



SWM Solid Waste Management

R-SWM Rural Solid Waste Management

HH Households

Group of family living in a house. These are one of the stakeholders for implementing R-SWM and SWM.

PET Polyethylene Terephthalate

The type of plastic most commonly used in water and soft drink bottles.

HDPE High Density Polyethylene

The type of hard plastic most commonly used shampoo/cleaner bottles, bottle caps and some plastic bags.

PP Polypropylene

Polypropylene uses range from plastic packaging, plastic parts for machinery and equipment and even fibers and textiles.



PREVENT PLASTICS

Prevent Plastics Myanmar



+95 9 45492 7732



info@preventplastics.org



<https://preventplastics.org>



PreventPlastics



prevent-plastics



Myanmar_PP

This publication is produced by Prevent Plastics & Thant Myanmar with support from the EU-funded SWITCH-Asia Programme. The content and opinions expressed herein are those of the author(s) and do not necessarily reflect the position or policy of the EU or SWITCH-Asia, and no official endorsement should be inferred

©2024 Prevent Plastics. All rights reserved. Licensed to the European Union under conditions.



Partners

